

# 1104D-E44TAG2

# 1100

120.1 kWm (Gross) @ 1800 rpm  
105.1 kWm (Gross) @ 1500 rpm

## Electropak

Series

### Basic technical data

Number of cylinders	4
Cylinder arrangement	Vertical in-line
Cycle	4 stroke
Induction system	Turbocharged, air to air charge cooled
Compression ratio	16.7:1
Bore	105 mm
Stroke	127 mm
Cubic capacity	4.399 litres
Direction of rotation	Anticlockwise when viewed from flywheel
Direction of rotation	Clockwise when viewed from front of engine
Firing order	1, 3, 4, 2

### Estimated total weight of IOPU

Dry	439 kg
Wet	448 kg

### Overall dimensions

Height	1087 mm
Length	1358 mm
Width (including mounting brackets)	746 mm

### Centre of gravity

Forward from rear of block	237.0 mm
Above centre line of block	167.0 mm
Offset to RHS of centre line	-1.5 mm

### Moments of inertia

Engine rotational excluding crank pulley and flywheel	0.124 kgm <sup>2</sup>
Flywheel	1.2 kgm <sup>2</sup>

### Performance

**Note:** All performance data based on operation to ISO Standard reference conditions.

Steady state speed stability at constant load	± 0.25%
Cyclic irregularity at rated power with 1.2 kgm <sup>2</sup> flywheel	TBA

### Test conditions

Air temperature	25°C
Barometric pressure	100 kPa
Relative humidity	30%
Air inlet restriction at rated speed	3 kPa
Exhaust back pressure at rated speed (nominal)	15 kPa(60Hz) / 6 kPa(50Hz)

### Sound level

Estimated Electropak sound power level @ 1 metre without inlet and exhaust	105.5 dB(amps)
--	----------------

**Note:** If the engine is to operate in ambient conditions other than those of the test conditions, suitable adjustments must be made for these changes. For full details, contact Perkins Technical Service Department.

### Emissions capability

Certified against the requirements of EU (EU 97/68/EC Stage IIIa) legislation for non-road mobile machinery, powered by constant speed engines.

## General installation

Designation	Units	TAG2 60Hz		TAG2 50Hz	
		Prime	Standby	Prime	Standby
Gross engine power	kWb	109.7	120.1	95.8	105.1
ElectropaK nett engine power	kWm	104.2	114.6	91.3	100.6
Brake mean effective pressure	kPa	1662	1820	1742	1911
Combustion air flow (at rated speed)	m <sup>3</sup> /min	8.64	8.82	6.42	6.74
Exhaust gas flow (maximum)	m <sup>3</sup> /min	19.48	20.15	16.41	17.4
Exhaust gas mass flow (maximum)	kg/min	10.18	10.37	7.73	8.05
Exhaust gas temperature in manifold maximum	°C	634	659	657	675
Boost pressure ratio					
Overall thermal efficiency (nett)		39.5%	40.1%	40.6%	40.8%
Typical genset electrical output (0.8 pf 25°C)	KVA	113.6	125.0	100.0	110.0
	kWe	90.9	100.0	80.0	88.0
Assumed alternator efficiency	%	90.0	90.0	90.4	90.2

## Energy balance

Designation	Units	TAG2 60Hz		TAG2 50Hz	
		Prime	Standby	Prime	Standby
Energy in fuel	kWt	277.5	299.5	236.2	257.5
Energy to power output (gross)	kWt	109.7	120.1	95.8	105.1
Energy to cooling fan	kWm	5.0	5.0	4.0	4.0
Energy to power (nett)	kWm	104.2	114.6	91.3	100.6
Energy to exhaust	kWt	86.3	91.3	70.1	74.8
Energy to coolant and oil	kWt	50.6	54.9	47.1	51.9
Energy to charge cooler	kWt	17.0	18.1	10.6	11.9
Energy to radiation	kWt	14.4	15.6	13.1	14.3

## Cooling system

### Cooling pack

Overall weight (wet) .....	68.5 kg
Overall face area of matrix .....	0.43 m <sup>2</sup>
Width of matrix .....	629 mm
Height of matrix .....	690 mm

### Radiator

Face area .....	0.3 m <sup>2</sup>
Number of rows and material .....	38 rows, Aluminium
Matrix density and material .....	10 fins per inch, Aluminium
Width of matrix .....	438 mm
Height of matrix .....	690 mm
Maximum top tank temperature .....	108°C
Pressure cap setting (minimum) .....	110 kPa

### Charge cooler

Face area .....	0.13 m <sup>2</sup>
Number of rows and materials .....	9 rows, Aluminium
Matrix density and material .....	7.5 fins per inch, Aluminium
Width of matrix .....	191 mm
Height of matrix .....	690 mm

### Fan

Diameter .....	559 mm
Drive ratio .....	1.25:1
Number of blades .....	7
Blade material .....	Composite
Type .....	Pusher

### Coolant

Total system capacity	
With radiator .....	17.0 litres
Without radiator .....	7.0 litres
Coolant pump drive .....	Gear
Coolant pump drive ratio .....	2:1
Maximum top tank temperature .....	110°C
Temperature rise across engine (rating dependent) .....	6.6 - 7.0°C
Thermostat operation range .....	82 - 97°C

**Recommended coolant:** 50% ethylene glycol with a corrosion inhibitor (BS 658 :1992 or MOD AL39) and 50% clean fresh water.

### Duct allowance

Duct allowance with 50% glycol @ 60Hz		
°C	kPa	m <sup>3</sup> /min
53	0	218
50	120	184
46	200	154

Duct allowance with 50% glycol @ 50Hz		
°C	kPa	m <sup>3</sup> /min
53	0	182
50	120	153
46	200	128

## Cold start recommendation

Minimum required cranking speed over TDC 60 rpm			
	5 to -10°C	-10 to -20°C	-20 to -25°C
Oil	15W40	10W40	5W40
Starter	AZE		
Battery	1 x 950 CCA		
Cranking current	600 amps		
Aids	None	Glowplugs	
Minimum mean cranking speed	130 rpm	100 rpm	100 rpm

**Note:** Battery capacity is defined by the 20 hour rate.

**Note:** If a change to a low viscosity oil is made, the cranking torque necessary at low ambient temperatures is much reduced. The starting equipment has been selected to take advantage of this. It is important to change to the appropriate multigrade oil in anticipation of operating in low ambient temperatures.

## Fuel system

Type of injection .....	Direct
Fuel injection pump .....	Common rail
Fuel atomiser .....	Unit injector / multi-hole
Nozzle opening pressure .....	160 MPa
Maximum allowable fuel temperature .....	80°C
Fuel lift pump delivery .....	200 l/h

### Fuel lift pump

Maximum flow through customer filter .....	130 litres/hour
Maximum fuel supply restriction at lift pump .....	40 kPa
Maximum fuel return restriction @ low idle .....	50 kPa
Maximum fuel return flow .....	6.6 m <sup>3</sup> /min
Maximum suction head .....	17 kPa (1.7 m)
Maximum static pressure head .....	10 kPa (1.0 m)
Governor type .....	Control by ECM
Speed control to .....	ISO 8528, G3

### Fuel specification

USA Fed Off Highway EPA2D 89.330-96	
Density (kg/l @ 15°C) .....	0.8373
Viscosity (mm <sup>2</sup> /s @ 40°C) .....	3.086
Sulphur content .....	0.02
Cetane number .....	53.8

## Fuel consumption litres/hour

60Hz Power Rating			
110%	100%	75%	50%
29.85	27.65	22.24	15.91

50Hz Power Rating			
110%	100%	75%	50%
25.65	23.54	20.36	14.63

## Electrical system

Alternator type .....	8SI
Alternator voltage .....	12 volts
Alternator output .....	65 amps
Starter motor type .....	AZE
Starter motor voltage .....	12 volts
Starter motor power .....	3.2 kW
Number of teeth on flywheel .....	126
Number of teeth on starter pinion .....	10
Minimum cranking speed .....	130 rpm
Starter solenoid maximum pull-in current @ 0°C .....	TBA
Starter solenoid maximum hold-in current @ 0°C .....	TBA

## Exhaust system

Maximum back pressure .....	15 kPa
Exhaust outlet size .....	64 mm
Crankcase breathing system type .....	Open circuit

## Induction system

Maximum air intake restriction	
Clean filter .....	3 kPa
Dirty filter .....	5 kPa
Air filter type .....	2 stage cyclonic/paper element

## Load acceptance

Initial load application when engine reaches rated speed, 15 seconds (maximum) after engine starts to crank		
Prime power %	Transient frequency deviation %	Frequency recovery time seconds
72	7.1	1.02

- The above complies with the requirements of classifications 3 and 4 of ISO 8528-12 and G2 operating limits stated in ISO 8528-5
- The above figures were obtained under test conditions as follows:

Minimum engine block temperature .....	45°C
Alternator efficiency .....	90%
Ambient temperature .....	15°C
Governing mode .....	Isochronous
Mechanical governing .....	4 % ±1 %
Alternator inertia .....	8 kgm <sup>2</sup>
Flywheel inertia .....	14 kgm <sup>2</sup>
Under frequency roll off point (UFRO) set to .....	Hz below rated
UFRO rate set to .....	.2% voltage / 1% frequency
LAM on/off .....	Off

All tests were conducted using an engine which was installed and serviced to Perkins Engines Company Limited recommendations.

## Mountings

Maximum static bending moment at rear face of block .....	791 N
Flywheel housing .....	SAE3

## Lubrication system

Lubricating oil capacity total system .....	8.4 litres
Maximum sump capacity .....	6.9 litres
Minimum sump capacity .....	5.6 litres
Maximum engine operating angles	
Front up, front down, right side or left side .....	24°

## Lubricating oil pressure

Relief valve opens pressure .....	415 kPa
Pressure at maximum no-load speed .....	470 kPa
Oil temperature (continuous operation) .....	125°C
Oil temperature (maximum intermittent operation) .....	135°C
Oil consumption at full load as a % of fuel consumption .....	0.10%

## Recommended SAE viscosity

A single or multigrade oil must be used which conforms to API-CC/SE or CCMC-D1, see illustration below:

Recommended oil specification .....

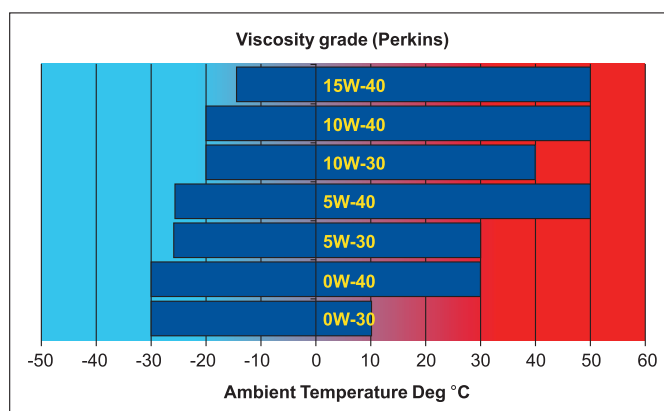

# 1104D-E44TAG2 Electropak - left side view

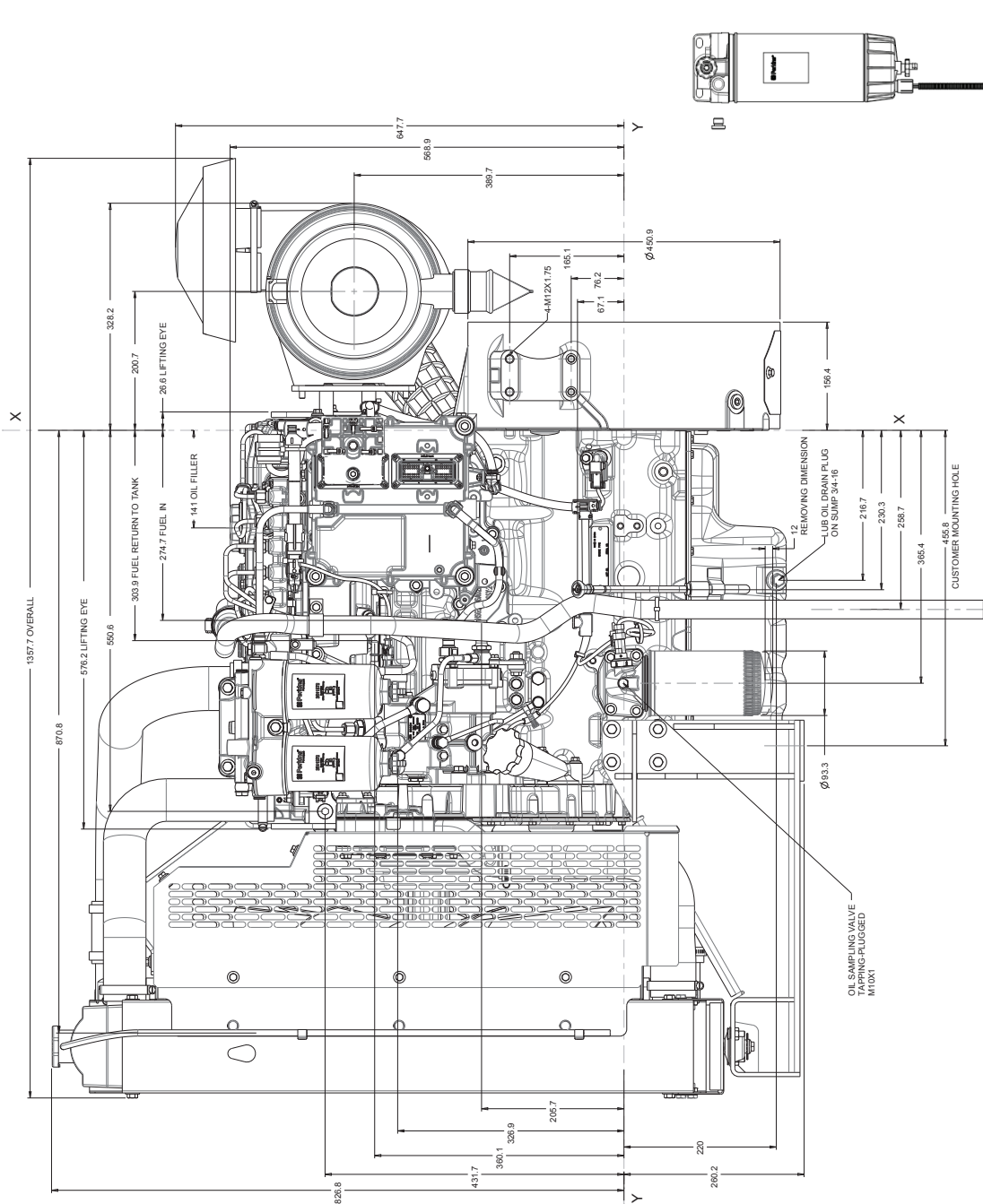

# 1104D-E44TAG2 Electropak - front view

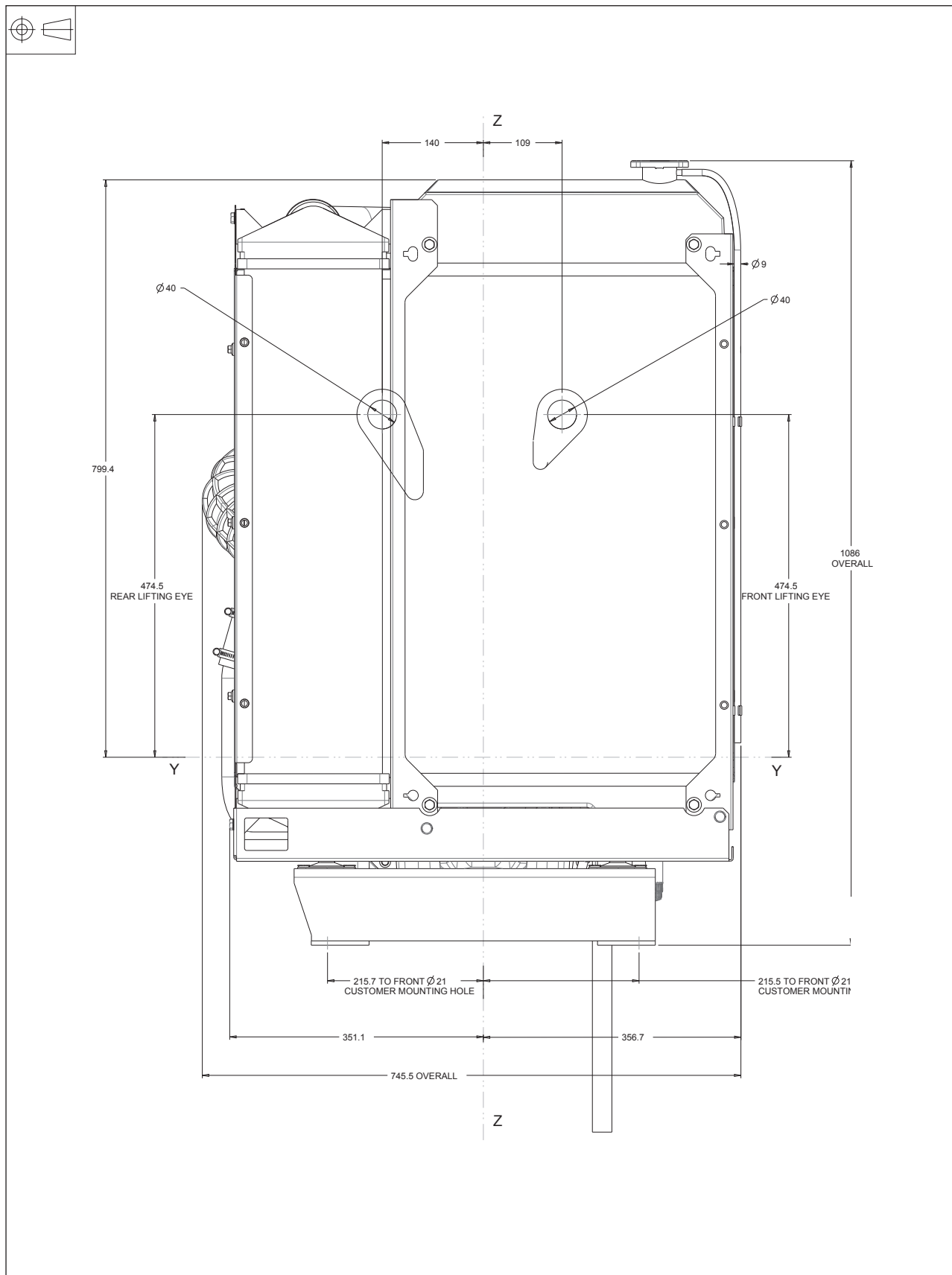

# 111104D-E44TAG2 Electropak- right side view

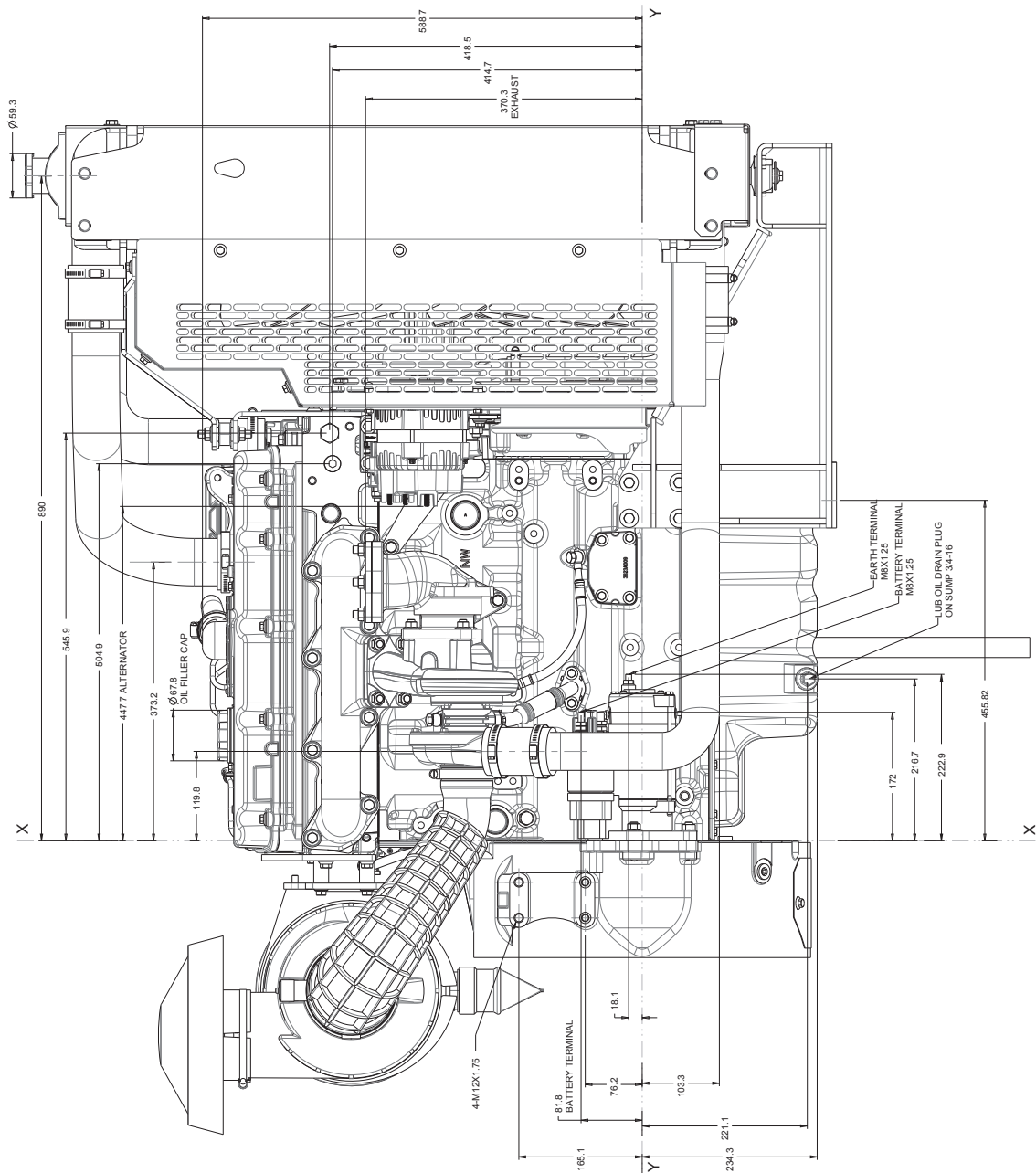

# 1104D-E44TAG2 Electropak - rear view

